

Installation Guide Windposts

Ancon Windposts

Panels of masonry with openings or very large masonry panels can be difficult to design. Ancon Windposts are designed to span vertically between floors to provide additional lateral support for panels of masonry.

Top & Bottom Connections

Top and bottom connections are designed with slotted holes to allow adjustment. Where cast-in channels are used parallel to the slab edge, a serrated pad and washer must be provided. Where expansion bolts are used, round holes or slots parallel to the slab edge will suffice. **The top connection should also have a vertical slot or slots (no serrations) to permit movement of the frame.**

Connections to the structural frame are determined prior to Manufacture/Supply, therefore the following rules should be followed.

1. Only use the fixings supplied, as these are integral to the design.
2. Use all normal/serrated washers provided, and tighten nuts to specified tightening torques. (see Installation Guide – Bolts)
3. Dimensional positioning of the Windpost should be to either structural engineers or specialist details.
4. Ensure all Windposts are installed vertical in both planes, thus allowing the ties to slide in the slots if expansion/contraction of the frame occurs.

Tie Installation

Wall ties should be fitted in each slot and have a minimum embedment of 50mm into each leaf. We suggest tie lengths which achieve a recommended embedment of between 62.5mm and 75mm, allowing for tolerance for cavity variations.

Ancon WP2 Installation Details

The design of Ancon WP2 Windposts assumes full restraint to the longer leg of the post located within the vertical masonry joint. To prevent lateral movement of the post within this joint and ensure the windpost performs to its full capacity, it is essential that this joint is tightly packed with mortar.

Safety Precautions

Ancon stainless steel products are produced from sheared plate. As with all such industrial fabrications, these may present sharp edges. **Suitable personal protective equipment should be worn at all times during handling and installation.**

Typical Bottom Connection

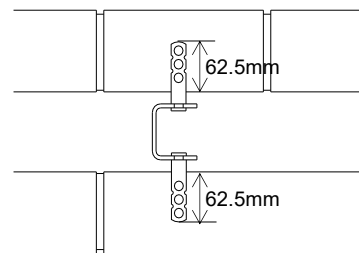
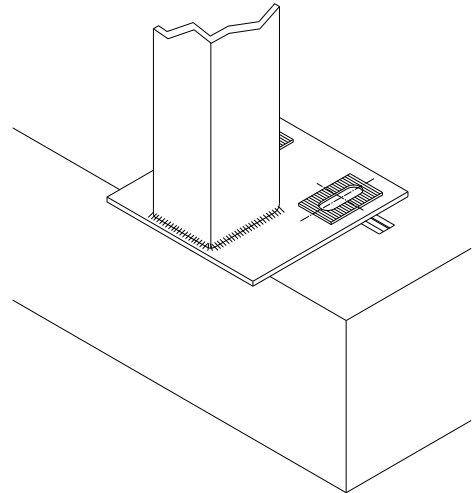

**Tie Embedment
(WP1/WP3)**

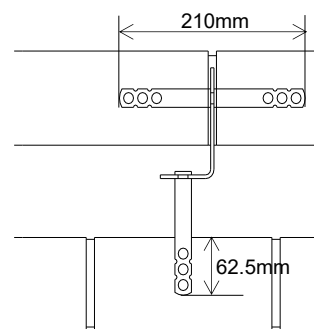

**Tie Embedment
(WP2)**